

# Buildings 1-2-3 and Building 4 First Floor Plan

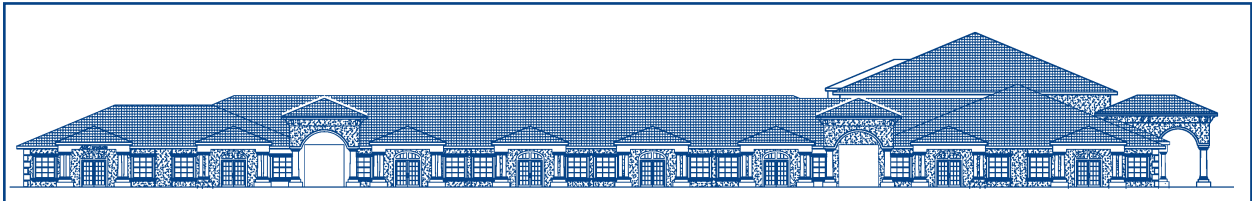

## GALLERIA ON VENICE AVENUE



### Design Options and Unit Size Flexibility Available

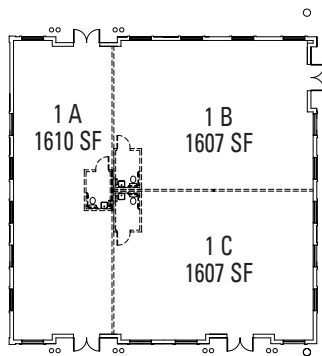

**BUILDING 1**

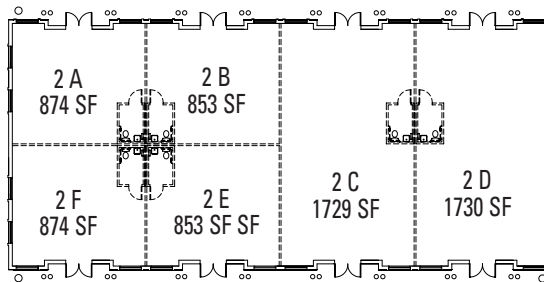

**BUILDING 2**

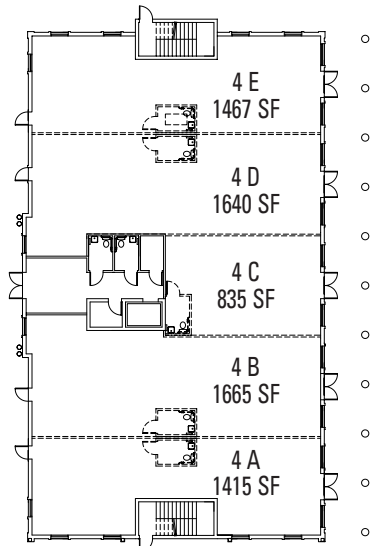

**BUILDING 4  
First Floor**

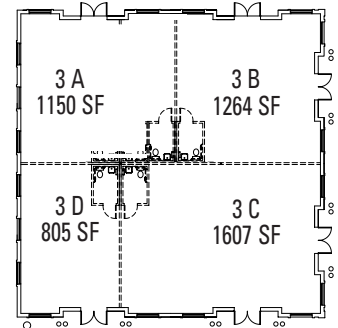

**BUILDING 3**

*Square footage of units as listed below may vary from square footage listed in the Condominium Documents. For purposes of marketing material unit square footage is approximate size and are based on unit outside walls to center of unit interior adjoining walls.*

[www.GalleriaOnVeniceAvenue.com](http://www.GalleriaOnVeniceAvenue.com)

**941.486.0068**

# Site Plan/Space Availability



5

<b>BUILDING 1</b>	<b>RETAIL</b>	<b>4900 SF</b>	<b>BUILDING 5</b>	<b>RETAIL</b>	<b>4900 SF</b>	<b>BUILDING 9</b>	<b>MEDICAL</b>	<b>8666 SF</b>
<b>BUILDING 2</b>	<b>RETAIL</b>	<b>7068 SF</b>	<b>BUILDING 6/F1</b>	<b>RETAIL</b>	<b>7800 SF</b>	<b>BUILDING 10</b>	<b>MEDICAL</b>	<b>8666 SF</b>
<b>BUILDING 3</b>	<b>RETAIL</b>	<b>4900 SF</b>	<b>BUILDING 6/F2</b>	<b>OFFICE</b>	<b>7800 SF</b>	<b>OUTPARCEL/W</b>		<b>1.4 Acres</b>
<b>BUILDING 4/F1</b>	<b>RETAIL</b>	<b>7800 SF</b>	<b>BUILDING 7</b>	<b>RETAIL</b>	<b>5415 SF</b>	<b>OUTPARCEL/E</b>		<b>1.25 Acres</b>
<b>BUILDING 4/F2</b>	<b>OFFICE</b>	<b>7800 SF</b>	<b>BUILDING 8</b>	<b>RETAIL</b>	<b>4900 SF</b>			

*Square footage of buildings as listed above may vary from square footage listed in the Condominium Documents. For the purpose of marketing materials, unit square footage is approximate size and is based on unit outside wall dimensions.*